

## Portable dry powder extinguisher PZ6A-PZ9A-PZ12A ABC



Type	Contents	H mm	ø mm	kg	Fire class	BENOR EN 3-norm	Insurance rate	Code Somati
PZ6A ABC	6 kg	560	170	11,1	34 A - 233 B	B98/101-2	1	115006
PZ9A ABC	9 kg	670	170	14,9	43 A - 233 B	B98/102-2	1 ½	115009
PZ12A ABC	12 kg	690	185	20,0	55 A - 233 B	B98/103-2	1 ½	115012



**PROTECTING TODAY'S FUTURE**

## Portable dry powder extinguisher PZ6A-PZ9A-PZ12A ABC

The portable dry powder extinguisher is in accordance to the NBN EN 3, point 1 to 5.

The extinguisher is provided with a BENOR label which attests this conformity.

The extinguisher is also in accordance to the tests described in the TN105 of the NVBB, and carries the NVBB label.

The outside of the container is electrostatically red powdered and enamelled.

Each container has been tested at 25 bar. The bursting pressure is higher than 55 bar while the working pressure is about 12 bar.

The cover is made of brass. So it can be opened and closed frequently. The percussion button is made of polyamid plastic and has a large surface in order to facilitate pushing down the break pin.

The powder is ejected through a flexible swiveling hose. The delivery is controlled by a spray gun made of high-quality polyamid. A membrane prevents humidity entering into the powder.

The cartridge with its cup and the CO<sub>2</sub> immersion tube are mounted next to the cover to facilitate re-filling and exclude damage during the assembly and disassembly. The content of the cartridge is :

- 130 g CO<sub>2</sub> for the PZ6
- 170 g CO<sub>2</sub> for the PZ9
- 200 g CO<sub>2</sub> for the PZ12

Thanks to its easy operation and stable construction this is a convenient and user-friendly fire extinguisher, also for left-handers.

### Components :

1. pinch tap
2. rubber hose
3. handle
4. safety catch
5. push button
6. humidity membrane
7. CO<sub>2</sub> immersion tube
8. cartridge
9. suspension bracket
10. container
11. riser tube
12. extinguishing powder

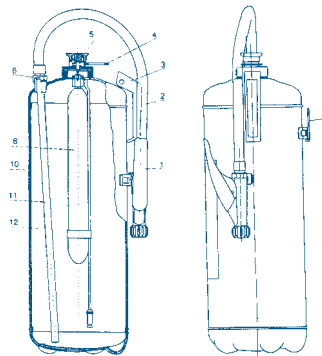

The wall bracket is always included.

RENTAL, MAINTENANCE, INSPECTION AND recharging  
of EXTINGUISHERS.  
MAINTENANCE SERVICES ALL OVER THE COUNTRY.



### PROTECTING TODAY'S FUTURE